

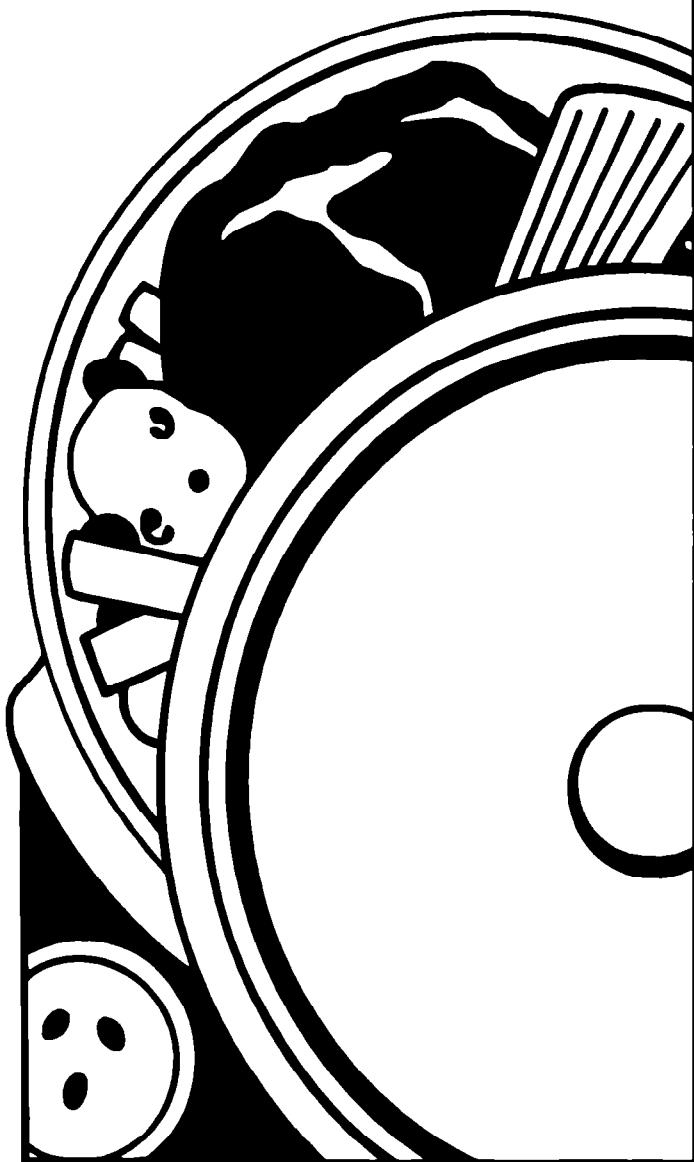

# Use And Care

## G U I D E



<b>A Note To You</b>	<b>2</b>
<b>Understanding Microwave Oven Safety</b>	<b>3</b>
<b>Precautions To Avoid Possible Exposure To Excessive Microwave Energy</b>	<b>5</b>
<b>Installation Instructions</b>	<b>8</b>
<b>Getting To Know Your Microwave Oven</b>	<b>10</b>
<b>Using Your Microwave Oven</b>	<b>18</b>
<b>Caring For Your Microwave Oven</b>	<b>31</b>
<b>Cooking Guide</b>	<b>32</b>
<b>Questions And Answers</b>	<b>36</b>
<b>If You Need Assistance Or Service</b>	<b>37</b>
<b>Warranty</b>	<b>40</b>

**1-800-253-1301**

Call us with questions or comments.

**MICROWAVE OVEN**

5/94

**MODEL MT1066XB**

**A NOTE TO YOU**

# A Note To You

**Thank you for buying a Whirlpool® appliance.**

You have purchased a quality, world-class home appliance. Years of engineering experience have gone into its manufacturing. To ensure that you will enjoy many years of trouble-free operation, we have developed this Use and Care Guide. It is full of valuable information on how to operate and maintain your appliance properly and safely. Please read it carefully. Also, please complete and mail the Ownership Registration Card provided with your appliance. This will help us notify you about any new information on your appliance.

**Your safety is important to us.**

This guide contains safety symbols and statements. Please pay special attention to these symbols and follow any instructions given. Here is a brief explanation of the use of each symbol.

**⚠ WARNING**

This symbol will help alert you to such dangers as personal injury, burns, fire and electrical shock.

**⚠ CAUTION**

This symbol will help you avoid actions which could cause product damage (scratches, dents, etc.) and damage to your personal property.

**Our Consumer Assistance Center number, 1-800-253-1301, is toll-free, 24 hours a day.**

If you ever have a question concerning your appliance's operation, or if you need service, first see "If You Need Assistance Or Service" on page 37. If you need further help, feel free to call our Consumer Assistance Center. When calling, you will need to know your appliance's complete model number and serial number. You can find this information on the model and serial number plate (see diagram on page 12). For your convenience, we have included a handy place below for you to record these numbers, the purchase date from the sales slip and your dealer's name and telephone number. Keep this book and the sales slip together in a safe place for future reference.

Model Number \_\_\_\_\_  
Serial Number \_\_\_\_\_  
Purchase Date \_\_\_\_\_

Dealer Name \_\_\_\_\_  
Dealer Phone \_\_\_\_\_

# Understanding Microwave Oven Safety

## IMPORTANT SAFETY INSTRUCTIONS

Microwave ovens have been thoroughly tested for safe and efficient operation. However, as with any appliance, there are special installation and safety precautions which must be followed to ensure safe and satisfactory operation and prevent damage to the unit.

### **⚠ WARNING**

**To reduce the risk of burns, fire, electrical shock, injury to persons, exposure to excessive microwave energy, or damage when using the microwave oven, follow basic precautions, including the following:**

- Read all instructions before using the microwave oven.
- Read and follow the specific "PRECAUTIONS TO AVOID POSSIBLE EXPOSURE TO EXCESSIVE MICROWAVE ENERGY" found on page 5.
- This appliance must be grounded. Connect only to properly grounded outlet. See "GROUNDING INSTRUCTIONS" found on page 9.
- Install or locate this appliance only in accordance with the provided Installation Instructions found on page 8.
- Some products such as whole eggs in the shell and sealed containers—for example, closed glass jars—could explode and should not be heated in this oven.
- Do not heat, store or use flammable materials in or near the oven. Fumes could create a fire hazard or explosion.
- Use this appliance only for its intended use as described in this manual. Do not use corrosive chemicals or vapors in this appliance. This type of oven is specifically designed to heat or cook food. It is not designed for industrial or laboratory use.
- As with any appliance, close supervision is necessary when used by children.
- Do not operate this appliance if it has a damaged cord or plug, if it is not working properly, or if it has been damaged or dropped. Electrical shock, fire or other hazards could result.
- This appliance should be serviced only by qualified service personnel. Call an authorized Whirlpool® service company for examination, repair or adjustment.
- Do not cover or block any opening on the appliance. Fire could result.
- Do not store or use this appliance outdoors. Do not use this product near water—for example, near a kitchen sink, in a wet basement, or near a swimming pool, and the like.
- Do not immerse cord or plug in water.
- Keep cord away from heated surfaces.
- Do not let cord hang over edge of table or counter.
- See door surface and interior cleaning instructions on page 31.
- To reduce the risk of fire in the oven cavity:
  - Do not overcook food. Carefully attend appliance if paper, plastic, or other combustible materials are placed inside the oven to facilitate cooking. Paper could char or burn, and some plastics could melt if used when heating foods.
  - Do not deep fry in oven. Microwavable utensils are not suitable and it is difficult to maintain appropriate deep frying temperatures.

continued on next page

## UNDERSTANDING MICROWAVE OVEN SAFETY

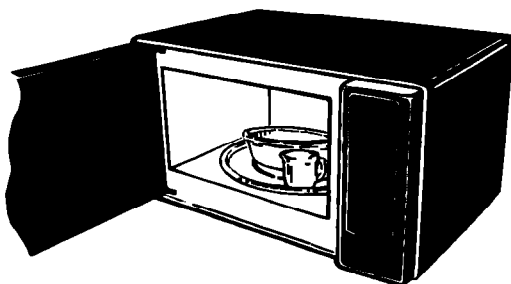

To reduce the risk of fire in the oven cavity (continued):

- **Test dinnerware or cookware before using.** To test a dish for safe use, put it into the oven with a cup of water beside it. Cook at 100% Cook Power for one minute. **If the dish gets hot and water stays cool, do not use it.** Some dishes (melamine, some ceramic dinnerware, etc.) absorb microwave energy, becoming too hot to handle and slowing cooking times. Cooking in metal containers not designed for microwave use can damage the oven, as can containers with hidden metal (twist-ties, foil lining, staples, metallic glaze or trim).
- Remove wire twist-ties from paper or plastic bags before placing bag in oven.

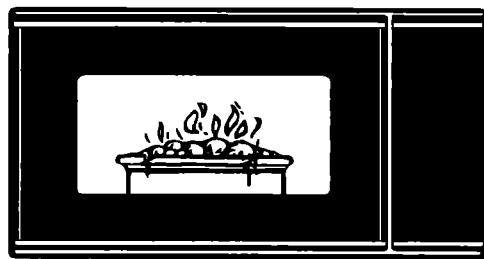

- If materials inside the oven should ignite, keep oven door closed, turn oven off, and disconnect the power cord or shut off power at the fuse or circuit breaker panel.

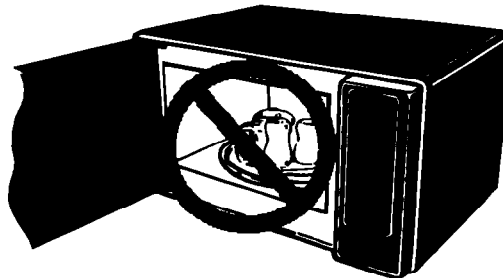

- Do not use the cavity for storage purposes. Do not leave paper products, cooking utensils, or food in the cavity when not in use.
  - Do not operate any heating or cooking appliance beneath this appliance.
  - Do not mount unit over or near any portion of a heating or cooking appliance.
  - Do not mount over a sink.
  - Do not store anything directly on top of the appliance when appliance is in operation.
- Read and follow “Operating safety precautions” starting on page 6.
    1. A short power-supply cord is provided to reduce the risks resulting from becoming entangled in or tripping over a longer cord.
    2. Longer cord sets or extension cords are available and may be used if care is exercised in their use.
    3. If a long cord or extension cord is used temporarily, (a) the marked electrical rating of the cord set or extension cord should be at least as great as the electrical rating of the appliance, (b) the extension cord must be a grounding-type, 3-wire cord that has a 3-blade grounding plug and a 3-slot receptacle that will accept the plug on the appliance, and (c) the longer cord should be arranged so that it will not drape over the countertop or tabletop where it can be pulled on by children or tripped over accidentally.

## UNDERSTANDING MICROWAVE OVEN SAFETY

4. A qualified electrician must install a properly grounded and polarized 3-prong receptacle near the appliance.

**– SAVE THESE INSTRUCTIONS –**

### **PRECAUTIONS TO AVOID POSSIBLE EXPOSURE TO EXCESSIVE MICROWAVE ENERGY...**

**Do not** attempt to operate this oven with the door open since open-door operation can result in harmful exposure to microwave energy. It is important not to defeat or tamper with the safety interlocks.

**Do not** place any object between the oven front face and the door or allow soil or cleaner residue to accumulate on sealing surfaces.

**Do not** operate the oven if it is damaged. It is particularly important that the oven door close properly and that there is no damage to the:

- (1) Door (bent),
- (2) Hinges and latches (broken or loosened),
- (3) Door seals and sealing surfaces.

**Do not** operate the microwave oven if the door window is broken.

The microwave oven should be checked for microwave leakage by qualified service personnel after a repair is made.

The oven should not be adjusted or repaired by anyone except properly qualified service personnel.

**Do not** operate the microwave oven with the outer cabinet removed.

# UNDERSTANDING MICROWAVE OVEN SAFETY

## Operating safety precautions

**⚠ WARNING**  
To reduce the risk of burns, fire, electrical shock, injury to persons, or damage when using the microwave oven, follow the precautions on pages 6-7.

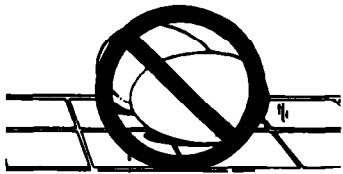

**Never cook or reheat a whole egg inside the shell.** Steam buildup in whole eggs may cause them to burst and burn you, and possibly damage the oven. **Slice** hard-boiled eggs before heating. In rare instances, poached eggs have been known to explode. **Cover** poached eggs and **allow** a standing time of one minute before cutting into them.



Stir before heating

**For best results, stir any liquid several times before heating or reheating.** Liquids heated in certain containers (especially cylindrical containers) may become overheated. The liquid may splash out with a loud noise during or after heating or when adding ingredients (coffee, etc.) resulting in harm to the oven and possible personal injury.

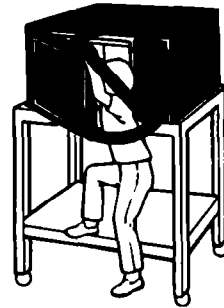

**Never lean on the door or allow a child to swing on it when the door is open.** Injury could result.

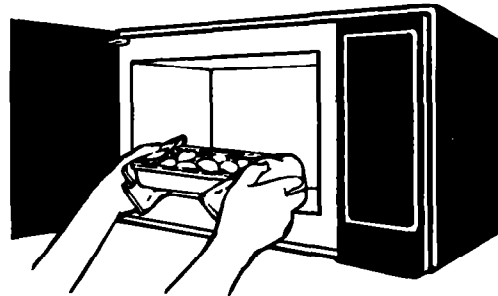

**Use hot pads.** Microwave energy does not heat containers, but the hot food does.

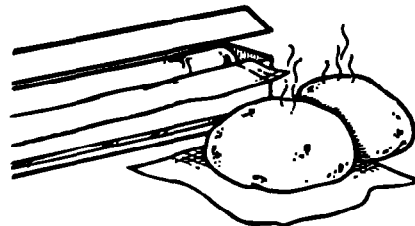

**Do not overcook potatoes.** Fire could result. At the end of the recommended cooking time, potatoes should be slightly firm because they will continue cooking during standing time. **After microwaving, wrap** potatoes in foil and **set aside** for 5 minutes. They will finish cooking while standing.

## UNDERSTANDING MICROWAVE OVEN SAFETY

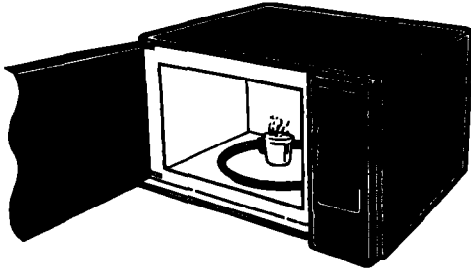

**Do not start a microwave oven when it is empty.** Product life may be shortened.  
If you practice programming the oven, put a container of water in the oven.

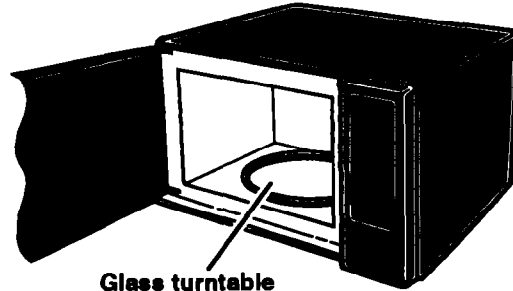

Glass turntable

**Do not operate in the microwave mode unless the glass turntable is securely in place and can rotate freely.** The turntable can rotate in either direction.

**Make sure the turntable is correct-side up in oven.** Carefully place cookware on turntable to avoid possible breakage.

**Handle turntable with care** when removing from oven to avoid possible breakage. If turntable cracks or breaks, contact your Whirlpool dealer for a replacement.

When you use a browning dish, the browning dish bottom must be at least  $\frac{3}{16}$  inch above the turntable. Follow directions supplied with browning dish.

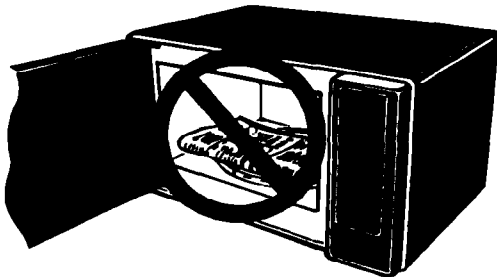

**Do not use newspaper or other printed paper in the oven.** Fire could result.

**Do not dry flowers, fruit, herbs, wood, paper, gourds or clothes in the oven.** Fire could result.



**Do not try to melt paraffin wax in the oven.** Paraffin wax will not melt in a microwave oven because it allows microwaves to pass through it.

### General information

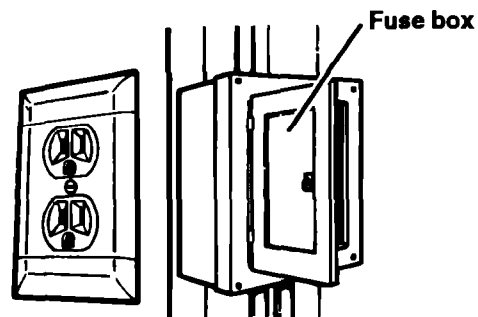

**If your electric power line or outlet voltage is less than 110 volts,** cooking times may be longer. Have a qualified electrician check your electrical system.

## INSTALLATION INSTRUCTIONS

# Installation Instructions

Before you begin operating the oven, carefully read the following instructions.

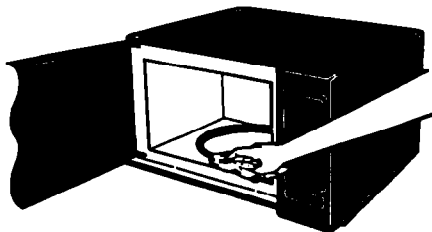

1. **Empty** the microwave oven and **clean** inside it with a soft, damp cloth. **Check** for damage such as misaligned door, damage around the door, or dents inside the oven or on the exterior. If there is any damage, do not operate the unit until it has been checked by an authorized Whirlpool® service technician and any repairs made.

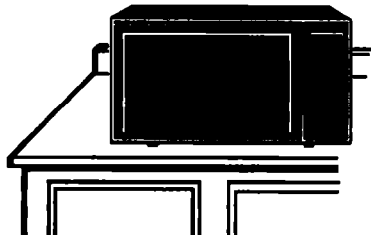

2. Put the oven on a cart, counter, table, or shelf that is strong enough to hold the oven and the food and utensils you put in it. **(The control side of the unit is the heavy side. Use care when handling.)** The weight of the oven is approximately 28 lbs (12.6 kg). The microwave oven should be at a temperature above 50°F (10°C) for proper operation.

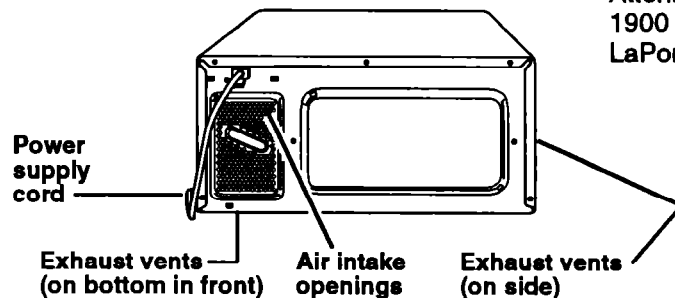

## ⚠ WARNING

### Fire, Electrical Shock, Excessive Exposure To Microwave Energy, Personal Injury and Product Damage Hazard

- Do not block the exhaust vents or rear air intake openings. Allow a few inches of space at back of oven where intake openings are located. Blocking the air intake openings and exhaust vents could cause damage to the oven and poor cooking results. Make sure the microwave oven legs are in place to ensure proper airflow.
- Do not install the oven next to or over a heat source (for example, a cooktop or range). Also, do not install oven in any area where excessive heat and steam are generated. This could cause a fire, electrical shock, excessive exposure to microwave energy, other personal injury or damage to the outside of the cabinet.

### Under-the-counter kits

You can fasten your microwave oven onto a wall or under a cabinet by using one of the following kits:

Kit No. 4378401 (for black model)

Kit No. 4378402 (for white model)

These kits are available from your Whirlpool Dealer. If your dealer does not stock the kit, it can be ordered, by kit part number, by writing to:

Whirlpool Corporation  
Attention: Customer Service Dept.  
1900 Whirlpool Drive  
LaPorte, IN 46350

## INSTALLATION INSTRUCTIONS

### 3. Electrical requirements

Observe all governing codes and ordinances. A 120 Volt, 60 Hz, AC only, 15 amp fused electrical supply is required.

(Time-delay fuse is recommended.) It is recommended that a separate circuit serving only this appliance be provided.

### 4. **GROUNDING INSTRUCTIONS**

#### **⚠ WARNING**

#### **Electrical Shock Hazard**

Improper use of the grounding plug can result in a risk of electrical shock. **DO NOT, UNDER ANY CIRCUMSTANCES, REMOVE THE POWER SUPPLY CORD GROUNDING PRONG.**

5. For your personal safety, this appliance must be grounded. In the event of an electrical short circuit, grounding reduces the risk of electrical shock by providing an escape wire for the electric current. This appliance is equipped with a polarized 3-prong grounding plug. It must be plugged into a correctly polarized mating 3-prong grounding type wall receptacle, properly installed and grounded in accordance with the National Electrical Code and local codes and ordinances. If a mating wall receptacle is not available or if you are not sure if the wall receptacle is properly grounded and polarized, have it checked by a qualified electrician.

It is the personal responsibility and obligation of the customer to have a properly grounded and correctly polarized 3-prong wall receptacle installed by a qualified electrician.

Consult a qualified electrician if the grounding instructions are not completely understood, or if doubt exists as to whether the appliance is properly grounded.

**It is not recommended to use an extension cord with your microwave oven, but if you find it necessary to do so temporarily (until a properly grounded and polarized, 3-prong receptacle is installed), use only a heavy duty, UL listed, 3-wire grounding type extension cord containing three 16-gauge (minimum) copper wires. It must not be longer than 10 feet (cords longer than 10 feet may affect the cooking performance of your microwave oven). The plug on the extension cord must fit into a 3-prong grounding type wall receptacle (as shown on this page) and the receptacle end of the extension cord must accept the 3-prong grounding plug of the microwave oven.**

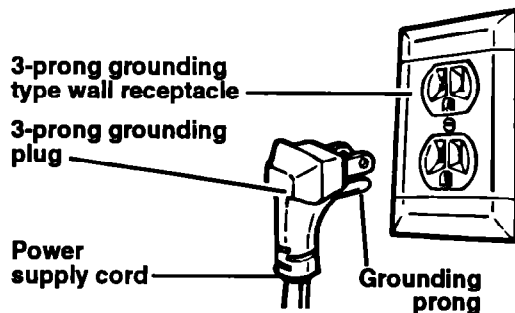

6.  To test the oven, plug it into the proper electrical outlet. Put about one cup (250 mL) of cold water in a glass container in the oven. Close the door. Make sure it latches. Follow the directions on page 19 to set the oven to cook for 2 minutes. When the time is up, the water should be heated.

7. **This microwave oven is designed for use in the household only and must not be used for commercial purposes.**

**Do not** remove the door, control panel or cabinet at any time. The unit is equipped with high voltage and should be serviced by an authorized Whirlpool® service technician.

**- SAVE THESE INSTRUCTIONS -**

# Getting To Know Your Microwave Oven

This section discusses the concepts behind microwave cooking and introduces you to the basics you need to know to operate your microwave oven. Please read this information before use.

<b>In This Section</b>	
	<b>Page</b>
<b>How microwave cooking works .....</b>	<b>10</b>
<b>Microwave oven features .....</b>	<b>12</b>
<b>Control panel features .....</b>	<b>13</b>
<b>Setting the clock .....</b>	<b>15</b>
<b>Using the Minute Timer .....</b>	<b>16</b>
<b>Using child lock .....</b>	<b>17</b>

## How microwave cooking works

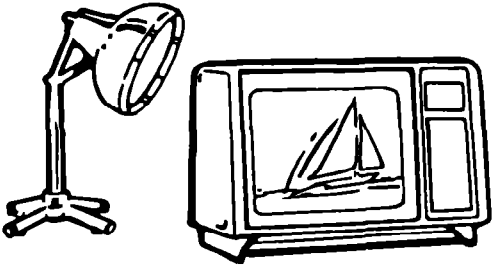

**Microwave ovens are safe.** Microwave energy is not hot. It causes food to make its own heat, and it's this heat that cooks the food.

Microwaves are like TV waves or light waves. You cannot see them, but you can see what they do.

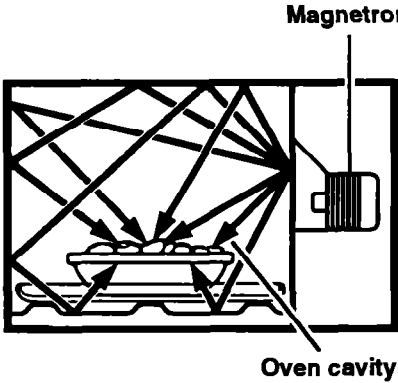

**A magnetron** in the microwave oven produces microwaves. The microwaves move into the oven where they contact food as it turns on the turntable.

## GETTING TO KNOW YOUR MICROWAVE OVEN

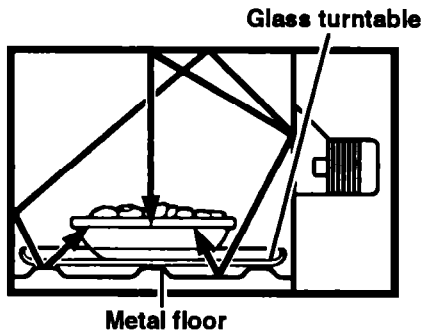

The glass turntable of your microwave oven lets microwaves pass through. Then they bounce off a metal floor, back through the glass turntable, and are absorbed by the food.

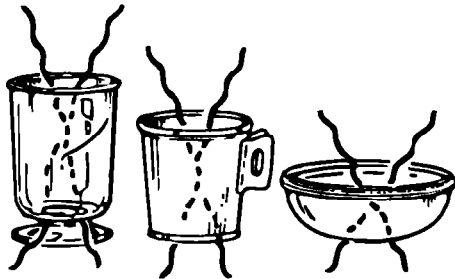

Microwaves pass through most glass, paper and plastics without heating them so food absorbs the energy. Microwaves bounce off metal pans so food does not absorb the energy.

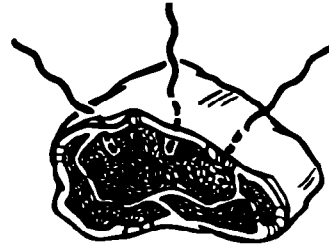

Microwaves may not reach the center of a roast. The heat spreads to the center from the outer, cooked areas just as in regular oven cooking. This is one of the reasons for letting some foods (for example, roasts or baked potatoes) stand for a while after cooking, or for stirring some foods during the cooking time.

The microwaves disturb water molecules in the food. As the molecules bounce around bumping into each other, heat is made, like rubbing your hands together. This is the heat that does the cooking.

### Radio interference

Operation of the microwave oven may cause interference to your radio, TV or similar equipment. When there is interference, it may be reduced or eliminated by taking the following measures:

- **Clean** door and sealing surfaces of the oven.
- **Adjust** the receiving antenna of radio or television.
- **Move** the receiver away from the microwave oven.
- **Plug** the microwave oven into a different outlet so that the microwave oven and receiver are on different branch circuits.

## Microwave oven features

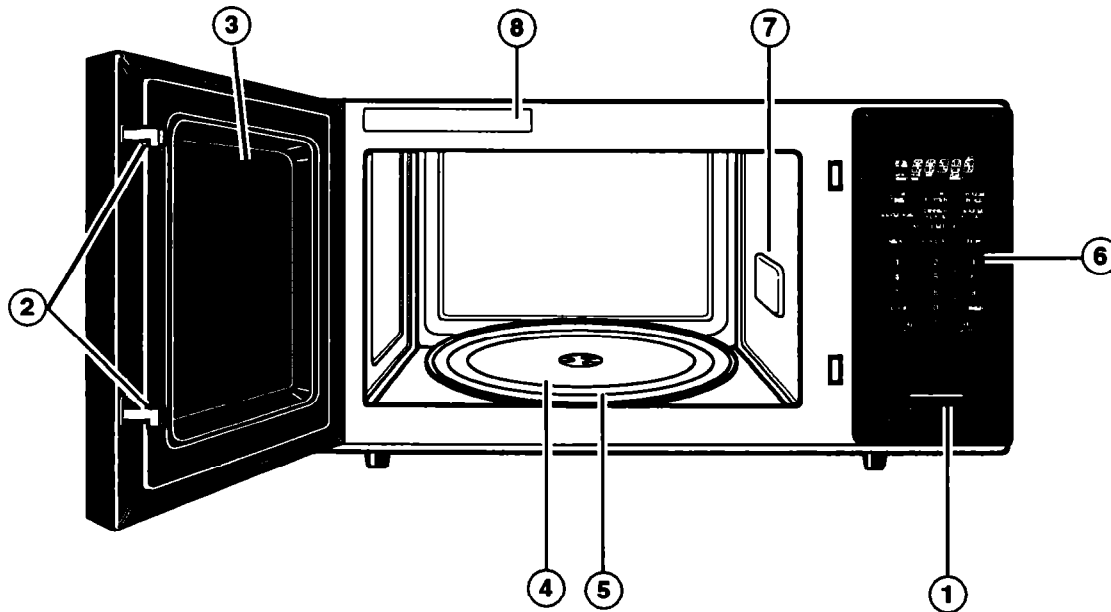

Your microwave oven is designed to make your cooking experience as enjoyable and productive as possible. To get you up and running quickly, the following is a list of the oven's basic features:

- 1. One-Touch Door Open Button.** Push to open door.
- 2. Door Safety Lock System.** The oven will not operate unless the door is securely closed.
- 3. Window with Metal Shield.** Shield prevents microwaves from escaping. It is designed as a screen to allow you to view food as it cooks.
- 4. Glass Turntable.** This turntable turns food as it cooks for more even cooking. It must be in the oven during operation for best cooking results. See pages 7, 11 and 31 for more details.
- 5. Turntable Support (under turntable).**
- 6. Control Panel.** Touch pads on this panel to perform all functions. See pages 13 and 14 for more information.
- 7. Light.** Automatically turns on when door is opened or when oven is operating.
- 8. Model and Serial Number Plate.**

## Control panel features

Your microwave oven control panel lets you select the desired cooking function quickly and easily. All you have to do is touch the necessary Command Pad. The following is a list of all the Command and Number Pads located on the control panel. For more information, see pages 15-30.

1. **Display.** This display includes a clock and indicators to tell you time of day, cooking time settings and cooking functions selected.
2. **COOK TIME.** Touch this pad followed by Number Pads to enter cooking times. See pages 19 and 21 for more information.
3. **COOK POWER.** Touch this pad followed by a Number Pad to set the amount of microwave energy released to cook the food. The higher the number, the higher the power or "cooking speed." See page 20 for more information. See the charts on pages 32 and 33 for specific Cook Powers to use for the food you are cooking.
4. **WARM HOLD.** Touch this pad to keep hot, cooked food safely warm in your microwave oven for up to 10 minutes. WARM HOLD can be used by itself, or it can automatically follow a cooking cycle. See page 26 for more information.
5. **BEVERAGE.** Touch this pad when heating one or two 8 oz cups of a beverage in your microwave oven. The oven will automatically heat for a preset time at a preset Cook Power. See page 23 for more information.
6. **DINNER PLATE.** Touch this pad to reheat a dinner plate of food in your microwave oven. The oven will automatically heat for a preset time at a preset Cook Power. See page 24 for more information.
7. **BAKED POTATO.** Touch this pad to bake one potato in your microwave oven. The oven will automatically heat for a preset time at a preset Cook Power. See page 25 for more information.
8. **MEAT.** Touch this pad followed by Number Pads to thaw frozen meat by weight. See page 27 for more information.

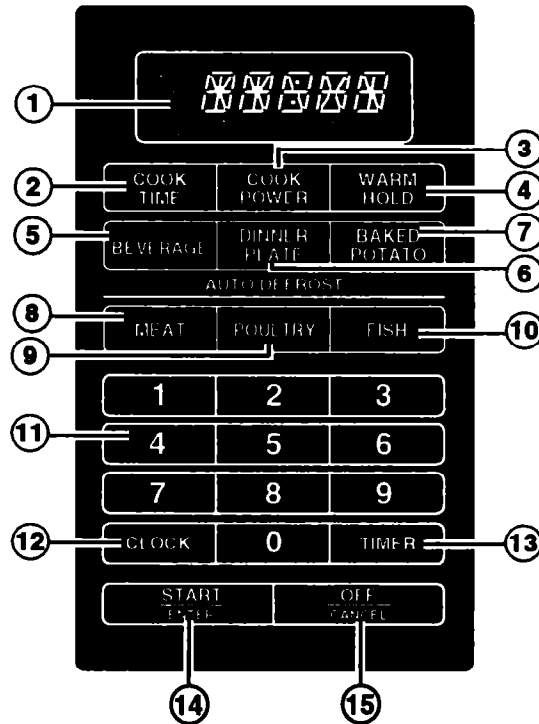

## GETTING TO KNOW YOUR MICROWAVE OVEN

9. **POULTRY.** Touch this pad followed by Number Pads to thaw frozen poultry by weight. See page 27 for more information.
10. **FISH.** Touch this pad followed by Number Pads to thaw frozen fish by weight. See page 27 for more information.
11. **Number Pads.** Touch Number Pads to enter cooking times, Cook Powers, and food weights.
12. **CLOCK.** Touch this pad to enter the correct time of day. See page 15 for more information.
13. **TIMER.** Touch this pad to set the Minute Timer. See page 16 for more information.
14. **START/ENTER.** Touch this pad to start a function that you have set. If you open the door after the oven begins to cook, retouch START/ENTER.
15. **OFF/CANCEL.** Touch this pad once to erase an incorrect command or twice to cancel a program during cooking. This pad will not erase time of day.

### NOTES:

- If you touch two Command Pads for the same cycle (for example, BAKED POTATO and WARM HOLD), the second command will cancel the first.
- If you attempt to enter unacceptable instructions, "ERROR" will appear on the Display and three tones will sound. Touch OFF/CANCEL and re-enter the instructions.

### Audible signals

Audible signals are available to guide you when setting and using your oven:

- A programming tone will sound each time you touch a pad.
- Three tones signal the end of a cooking cycle.

### Interrupting cooking

You can stop the oven during a cycle by opening the door. The oven stops heating and the fan stops, but the light stays on. To restart cooking, close the door and

TOUCH 

If you do not want to continue cooking:

- Close the door and the light goes off.

OR

• TOUCH 

# GETTING TO KNOW YOUR MICROWAVE OVEN

## Setting the clock

When your microwave oven is first plugged in or after a power failure, the Display will only show "0". If a time of day is not set, "0" will stay on the Display until you set the cooking time.

### NOTES:

- **You can** only set the clock if the oven is not cooking food.
- **If you touch in** an incorrect time, "ERROR" will appear on the Display and three tones will sound. Touch CLOCK and enter the correct time.
- **If you touch** OFF/CANCEL while setting the clock, the clock will be cleared and the Display will go blank.

### To set time:

#### 1. Choose setting.

TOUCH

CLOCK

YOU SEE



#### 2. Enter time of day.

Example for 5:30:

TOUCH

5

3

0

YOU SEE



#### 3. Complete entry.

TOUCH

CLOCK

YOU SEE

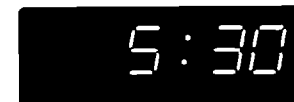

# GETTING TO KNOW YOUR MICROWAVE OVEN

## Using the Minute Timer

You can use the microwave oven controls as a minute timer. Use the Minute Timer for timing up to 99 minutes, 99 seconds.

**NOTE:** The oven will not operate while the Minute Timer is in use.

### 1. Touch **TIMER**.

TOUCH



YOU SEE



### 2. Enter time to be counted down.

Example for 1 minute, 30 seconds:

TOUCH



YOU SEE



### 3. Start countdown.

TOUCH



YOU SEE

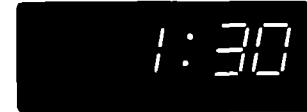

After one second, the Display will begin to count down:

**NOTE:** Opening the oven door will not stop the countdown.

YOU SEE

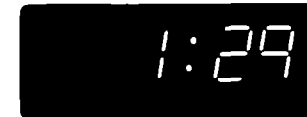

At end of countdown:

YOU SEE



(three tones will sound)

### 4. After countdown, open the door.

OR

TOUCH



YOU SEE

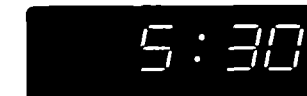

(time of day)

---

## Using child lock

Your oven has a lockout feature that inactivates the microwave power.

---

### To set child lock:

1. Touch OFF/CANCEL.

TOUCH



YOU SEE



(time of day)

---

2. Touch "0".

TOUCH



(press for about  
2 seconds)

YOU SEE



---

### To cancel child lock:

1. Touch "0".

TOUCH



(press for about  
2 seconds)

YOU SEE



YOU SEE



(time of day)

# Using Your Microwave Oven

This section gives you instructions for operating each microwave function. Please read these instructions carefully.

<b>In This Section</b>	
	<b>Page</b>
<b>Getting the best cooking results</b> .....	<b>18</b>
<b>Cooking at high cook power</b> .....	<b>19</b>
<b>Cooking at lower cook powers</b> .....	<b>20</b>
<b>Using BEVERAGE</b> .....	<b>23</b>
<b>Using DINNER PLATE</b> .....	<b>24</b>
<b>Using BAKED POTATO</b> .....	<b>25</b>
<b>Using WARM HOLD</b> .....	<b>26</b>
<b>Defrosting</b> .....	<b>27</b>
<b>Auto defrost chart</b> .....	<b>28</b>
<b>Defrosting tips</b> .....	<b>30</b>

## Getting the best cooking results

- **Although a new rating method\*** rates this oven at 625 watts, you may use a reliable cookbook and recipes developed for microwave ovens previously rated at 500-550 watts.
- **ALWAYS** cook food for the minimum recommended cooking time. Then **check** for doneness to avoid overcooking the food.
- **Stir, turn over or rearrange** food being cooked about halfway through the cook time for most even doneness with all recipes.
- **If a glass cover is not available, use** wax paper, paper towels or microwave-approved plastic wrap. **Turn back** a corner to vent steam during cooking.

\* IEC-705 Test Procedure. The IEC-705 Test Procedure is an internationally recognized method of rating microwave wattage output and does not represent an actual change to output power or cooking performance.

# USING YOUR MICROWAVE OVEN

## Cooking at high cook power

1. Put food in oven and close the door.

2. Set cooking time.

TOUCH

COOK  
TIME

YOU SEE



Example for 1 minute, 30 seconds:

TOUCH

1

3

0

YOU SEE

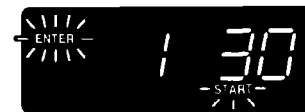

3. Start oven.

TOUCH

START  
ENTER

YOU SEE



After one second, the Display will begin to count down the cooking time:

YOU SEE

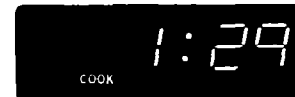

At end of cooking time:

YOU SEE



(three tones will sound)

continued on next page

## USING YOUR MICROWAVE OVEN

4. After cooking, open the door.

OR TOUCH



YOU SEE

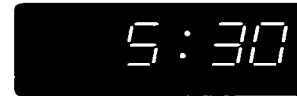

(time of day)

### Cooking at lower cook powers

For best results, some recipes call for lower Cook Powers. The lower the Cook Power, the slower the cooking. Each Number Pad also stands for a different percentage of Cook Power. Many microwave cookbook recipes tell you by number, percent or name which Cook Power to use.

The following chart gives the percentage of Cook Power each Number Pad stands for, and the Cook Power name usually used. It also tells you when to use each Cook Power.

COOK POWER	NAME	WHEN TO USE IT
Automatic 100% of full power	HIGH	Quick reheating of foods with high water content, such as beverages. If food contains eggs or cream, choose a lower power.
9=90% of full power		Heating large quantities of liquids, such as water or soup stock.
8=80% of full power		Reheating soups or casseroles.
7=70% of full power	MED-HIGH	Cooking and heating vegetables, fish, meat, etc. when you need a Cook Power lower than HIGH or when food is cooking too fast.
6=60% of full power		Cooking requiring special care, such as for high protein sauces, cheese and egg dishes, and casseroles that need to finish cooking.
5=50% of full power	MED	Starting cakes which must be finished on HIGH power or finishing cooking of a large roast.
4=40% of full power		Simmering stews, reheating pastries.
3=30% of full power	MED-LOW, DEFROST	Defrosting of foods such as bread, shellfish, and precooked foods.
2=20% of full power		Defrosting and softening butter, cheese and ice cream.
1=10% of full power	LOW	Keeping one food serving warm.

# USING YOUR MICROWAVE OVEN

1. Put food in oven and close the door.

2. Set cooking time.

TOUCH

COOK  
TIME

YOU SEE



Example for 7 minutes, 30 seconds:

TOUCH

7

3

0

YOU SEE



3. Set Cook Power.

TOUCH

COOK  
POWER

YOU SEE



Example for 50% Cook Power:

TOUCH

5

YOU SEE



4. Start oven.

TOUCH

START  
ENTER

YOU SEE



continued on next page

# USING YOUR MICROWAVE OVEN

After one second, the Display will begin to count down the cooking time:

YOU SEE



At end of cooking time:

YOU SEE



(three tones will sound)

---

5. After cooking, open the door. OR TOUCH



YOU SEE



(time of day)

# USING YOUR MICROWAVE OVEN

## Using BEVERAGE

BEVERAGE lets you heat one or two 8 oz cups of a beverage by touching just one pad.

### NOTES:

- **Touch** BEVERAGE once for one cup and twice for two cups.
- **If more time is needed**, cook in 20-second periods at high Cook Power. (See "Cooking at high cook power" on page 19.)

1. Place cup(s) of beverage in oven and close door.

2. Choose BEVERAGE.

Example for one 8 oz cup:

TOUCH



once

YOU SEE



YOU SEE



After four seconds, the Display will begin to count down the heating time:

At end of heating time:

YOU SEE



(three tones will sound)

3. After heating, open the door. OR TOUCH



YOU SEE



(time of day)

# USING YOUR MICROWAVE OVEN

## Using DINNER PLATE

DINNER PLATE lets you reheat a dinner plate of refrigerated food by touching just one pad. Before reheating, place meat and bulky vegetables to the outside of the plate. Cover with wax paper or plastic wrap.

### NOTES:

- **Touch DINNER PLATE** once for an 8 oz plate and twice for a 16 oz plate.
- **If more time is needed**, cook in 20-second periods at high Cook Power. (See "Cooking at high cook power" on page 19.)

1. Place plate of food on turntable and close door.

2. Choose DINNER PLATE.

Example for an 8 oz plate:

TOUCH



once

YOU SEE



After four seconds, the Display will begin to count down the reheating time:

YOU SEE



At end of reheating time:

YOU SEE



(three tones will sound)

3. After reheating food, open the door.

OR TOUCH



YOU SEE



(time of day)

## USING YOUR MICROWAVE OVEN

### Using BAKED POTATO

BAKED POTATO lets you bake one (6 oz) to four (24 oz) medium potatoes by touching one pad from one to four times.

Before baking, remember to pierce potato with a fork several times. After cooking, let potato stand 5 minutes wrapped in foil.

#### NOTES:

- **If more time is needed**, cook in 20-second periods at high Cook Power. (See "Cooking at high cook power" on page 19.)
- **To bake more than one potato:**
  - Touch **twice** – for 12 oz of potatoes
  - Touch **3 times** – for 18 oz of potatoes
  - Touch **4 times** – for 24 oz of potatoes

1. Place potato on paper towel on turntable and close door.

2. Choose BAKED POTATO.

Example for one potato:

TOUCH

BAKED  
POTATO

once

YOU SEE

AUTO COOK 6<sup>oz</sup>

AUTO COOK 20<sup>oz</sup>-

AUTO COOK TATO

After four seconds, the Display will begin to count down the baking time:

YOU SEE

AUTO COOK 4:36

At end of baking time:

YOU SEE

END

(three tones will sound)

3. After baking, open the door. OR TOUCH

OFF  
CANCEL

YOU SEE

5:30

(time of day)

## USING YOUR MICROWAVE OVEN

### Using WARM HOLD

You can safely keep hot, cooked food warm in your microwave oven for up to 10 minutes. You can use WARM HOLD by itself, or to automatically follow a cooking cycle.

#### NOTES:

- **WARM HOLD** operates for up to 60 minutes. However, you should not use WARM HOLD for more than 10 minutes. After 10 minutes, food will continue to cook.
- **Opening** the oven door cancels WARM HOLD. Close the door and touch WARM HOLD, then touch START/ENTER if additional WARM HOLD time is desired.
- **Food cooked covered** should be covered during WARM HOLD.
- **Pastry items** (pies, turnovers, etc.) should be uncovered during WARM HOLD.
- **Complete meals** kept warm on a dinner plate should be covered during WARM HOLD.

#### 1. Put hot, cooked food in oven and close the door.

#### 2. Choose setting.

TOUCH

WARM  
HOLD

YOU SEE



#### 3. Start oven.

TOUCH

START  
ENTER

YOU SEE



(the oven light and fan will come on)

#### To make WARM HOLD automatically follow another cycle:

- **While you are touching in cooking instructions**, touch WARM HOLD before touching START/ENTER.  
OR
- **After the oven starts operating**, touch OFF/CANCEL once, touch WARM HOLD, and then touch START/ENTER.
- **When the last cooking cycle is over**, you will hear two tones. "Hold" will come on while the oven continues to run.
- **You can set WARM HOLD to follow** AUTO DEFROST or COOK.

## USING YOUR MICROWAVE OVEN

### Defrosting

Your microwave oven automatically defrosts a variety of common meats at preset Cook Powers for preset times. The defrost cycle is programmed for meat, poultry, and fish. All you do is touch the Command Pad assigned to the desired category and enter the weight of the items being defrosted. Your microwave oven does the rest.

#### NOTES:

- See the "Auto defrost chart" on page 28 for defrosting directions for each food.
- **AUTO DEFROST** can only defrost up to 2.5 lbs of any food.
- **Oven will briefly pause** in middle of cycle. At that time you can rearrange food as needed. See "Auto defrost chart" on page 28 for further instructions.

1. Put frozen food in oven and close the door.

2. Choose setting.

Example for MEAT:

TOUCH

MEAT

YOU SEE



3. Enter food's weight  
(in pounds and tenths of a pound).

Example for 2.5 lbs:

TOUCH

2 5

YOU SEE



4. Start oven.

TOUCH

START  
ENTER

YOU SEE



(time counts down)

At end of defrosting time:

YOU SEE



(three tones will sound)

5. After defrosting, open  
the door.

OR TOUCH

OFF  
CANCEL

YOU SEE

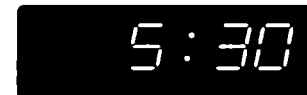

(time of day)

## USING YOUR MICROWAVE OVEN

### Auto defrost chart Meat setting

FOOD	AT PAUSE	SPECIAL INSTRUCTIONS
<b>Beef</b>		Meat of irregular shape and large, fatty cuts of meat should have the narrow or fatty areas shielded with foil at the beginning of a defrost cycle.
Ground Beef, Bulk	Remove thawed portions with fork. Turn over. Return remainder to oven.	Do not defrost less than 1/4 lb. Freeze in doughnut shape.
Ground Beef, Patties	Separate and rearrange.	Do not defrost less than two 4 oz patties. Depress center when freezing.
Round Steak	Turn over. Cover warm areas with aluminum foil.	Place on a microwavable roasting rack.
Tenderloin Steak	Turn over. Cover warm areas with aluminum foil.	Place on a microwavable roasting rack.
Stew Beef	Remove thawed portions with fork. Separate remainder. Return remainder to oven.	Place in a microwavable baking dish.
Pot Roast, Chuck Roast	Turn over. Cover warm areas with aluminum foil.	Place on a microwavable roasting rack.
Rib Roast	Turn over. Cover warm areas with aluminum foil.	Place on a microwavable roasting rack.
Rolled Rump Roast	Turn over. Cover warm areas with aluminum foil.	Place on a microwavable roasting rack.
<b>Lamb</b>		
Cubes for Stew	Remove thawed portions with fork. Return remainder to oven.	Place in a microwavable baking dish.
Chops (1 inch thick)	Separate and rearrange.	Place on a microwavable roasting rack.
<b>Pork</b>		
Chops (1/2 inch thick)	Separate and rearrange.	Place on a microwavable roasting rack.
Hot Dogs	Separate and rearrange.	Place on a microwavable roasting rack.
Spareribs, Country-Style Ribs	Turn over. Cover warm areas with aluminum foil.	Place on a microwavable roasting rack.
Sausage, Links	Separate and rearrange.	Place on a microwavable roasting rack.
Sausage, Bulk	Remove thawed portions with fork. Turn over. Return remainder to oven.	Place in a microwavable baking dish.
Loin Roast, Boneless	Turn over. Cover warm areas with aluminum foil.	Place on a microwavable roasting rack.

## USING YOUR MICROWAVE OVEN

### Fish setting

FOOD	AT PAUSE	SPECIAL INSTRUCTIONS
<b>Fish</b>		
Fillets	Turn over. Separate fillets when partially thawed.	Place in a microwavable baking dish. Carefully separate fillets under cold water.
Steaks	Separate and rearrange.	Place in a microwavable baking dish. Run cold water over to finish defrosting.
Whole	Turn over.	Place in a microwavable baking dish. Cover head and tail with foil; do not let foil touch sides of microwave oven. Finish defrosting by immersing in cold water.
<b>Shell Fish</b>		
Crabmeat	Break apart. Turn over.	Place in a microwavable baking dish.
Lobster Tails	Turn over and rearrange.	Place in a microwavable baking dish.
Shrimp	Separate and rearrange.	Place in a microwavable baking dish.
Scallops	Separate and rearrange.	Place in a microwavable baking dish.

### Poultry setting

FOOD	AT PAUSE	SPECIAL INSTRUCTIONS
<b>Chicken</b>		
Whole (up to 9½ lbs)	Turn over (finish defrosting breast-side down). Cover warm areas with aluminum foil.	Place chicken breast-side up on a microwavable roasting rack. Finish defrosting by immersing in cold water. Remove giblets when chicken is partially defrosted.
Cut Up	Separate pieces and rearrange. Turn over. Cover warm areas with aluminum foil.	Place on a microwavable roasting rack. Finish defrosting by immersing in cold water.
<b>Cornish Hens</b>		
Whole	Turn over. Cover warm areas with aluminum foil.	Place on a microwavable roasting rack. Finish defrosting by immersing in cold water.
<b>Turkey</b>		
Breast (under 6 lbs)	Turn over. Cover warm areas with aluminum foil.	Place on a microwavable roasting rack. Finish defrosting by immersing in cold water.

## USING YOUR MICROWAVE OVEN

### Weight conversion chart

You are probably used to food weights as being in pounds and ounces that are fractions of a pound (for example 4 ounces equals  $\frac{1}{4}$  pound). However, in order to enter food weight in AUTO DEFROST, you must specify pounds and tenths of a pound.

If the weight on the food package is in fractions of a pound, you can use the following chart to convert the weight to decimals.

NUMBER AFTER DECIMAL	EQUIVALENT OUNCE WEIGHT
.10	1.6
.20	3.2
.25     One-Quarter Pound	4.0
.30	4.8
.40	6.4
.50     One-Half Pound	8.0
.60	9.6
.70	11.2
.75     Three-Quarters Pound	12.0
.80	12.8
.90	14.4
1.00     One Pound	16.0

### Defrosting tips

- **When using AUTO DEFROST**, the weight to be entered is the net weight in pounds and tenths of pounds (the weight of the food minus the container).
- **Only use AUTO DEFROST** for raw food. AUTO DEFROST gives best results when food to be thawed is a minimum of 0°F (taken directly from a "true" freezer). If food has been stored in a refrigerator-freezer that does not maintain a temperature of 0°F or below, always program a lower food weight (for a shorter defrosting time) to prevent cooking the food.
- **If the food is stored outside** the freezer for up to 20 minutes, enter a lower food weight.
- **If the food is stored outside** the freezer for more than 20 minutes, and for defrosting ready-made food, defrost by time and power and let stand after defrosting.
- **The shape of the package** alters the defrosting time. Shallow rectangular packets defrost more quickly than a deep block.
- **Separate pieces** as they begin to defrost. Separated pieces defrost more easily.
- **You can use small pieces** of aluminum foil to shield foods like chicken wings, leg tips, and fish tails, but the foil must not touch the side of the oven. Foil can damage the oven lining.
- **Shield areas of food** with small pieces of foil if they start to become warm.
- **For better results, a preset standing time** is included in the defrosting time. This may make the defrosting time seem longer than expected. (For more information on standing time, see "Microwave cooking tips" on page 34.)

# Caring For Your Microwave Oven

To make sure your microwave oven looks good and works well for a long time, you should maintain it properly. For proper care, please follow these instructions carefully.

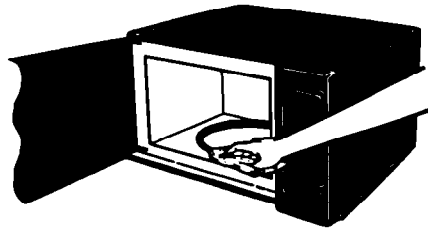

**Wipe** often with warm, sudsy water and a sponge or paper towel. You can remove the glass turntable to clean the oven cavity floor; however, this oven is designed to operate with the turntable in place. **Do not** operate the microwave oven when turntable is removed for cleaning. See page 7 for further information about the turntable.

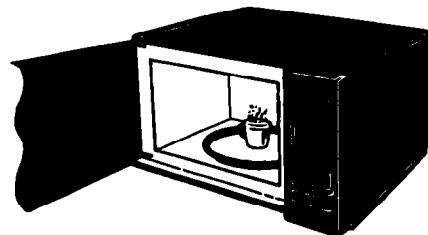

For stubborn soil, **boil** a cup of water in the oven for 2 or 3 minutes. Steam will soften the soil. To get rid of odors inside the oven, **boil** a cup of water with lemon juice.

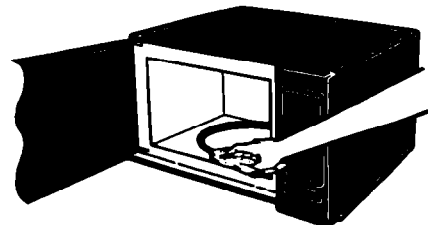

**Be sure to keep the areas clean where the door and oven frame touch when closed. Use only mild, nonabrasive soaps or detergents applied with a sponge or paper towel when cleaning surfaces. Rinse well.**

## ⚠ CAUTION

### Product Damage Hazard

Abrasive cleansers, steel-wool pads, gritty wash cloths, etc., could damage the control panel, and the interior and exterior oven surfaces. Use a sponge with a mild detergent or a paper towel with spray glass cleaner. Apply spray glass cleaner to paper towel; do not spray directly on oven.

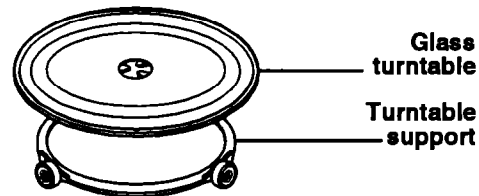

**To clean turntable and turntable support, wash in mild, sudsy water; for heavily soiled areas use a mild cleanser and scouring sponge. The turntable and turntable support are dishwasher-safe.**

# Cooking Guide

## Reheating chart

Times are approximate and may need to be adjusted to individual taste.

ITEM	STARTING TEMP	TIME/POWER	PROCEDURE
<b>Meat</b> (Chicken pieces, chops, hamburgers, meat loaf slices) 1 serving 2 servings	Refrigerated Refrigerated	1-2 min at 70% 2½-4½ min at 70%	Cover loosely.
<b>Meat Slices</b> (Beef, ham, pork, turkey) 1 or more servings	Room temp Refrigerated	45 sec-1 min per serving at 50% 1-3 min per serving at 50%	Cover with gravy or wax paper. Check after 30 sec per serving.
<b>Stirrable Casseroles and Main Dishes</b> 1 serving 2 servings 4-6 servings	Refrigerated Refrigerated Refrigerated	2-4 min at 100% 4-6 min at 100% 6-8 min at 100%	Cover. Stir after half the time.
<b>Nonstirrable Casseroles and Main Dishes</b> 1 serving 2 servings 4-6 servings	Refrigerated Refrigerated Refrigerated	5-8 min at 50% 9-12 min at 50% 13-16 min at 50%	Cover with wax paper.
<b>Soup, Cream</b> 1 cup 1 can (10¾ oz)	Refrigerated Room temp	3-4½ min at 50% 5-7 min at 50%	Cover. Stir after half the time.
<b>Soup, Clear</b> 1 cup 1 can (10¾ oz)	Refrigerated Room temp	2½-3½ min at 100% 4-5½ min at 100%	Cover. Stir after half the time.
<b>Pizza</b> 1 slice 1 slice 2 slices 2 slices	Room temp Refrigerated Room temp Refrigerated	15-25 sec at 100% 30-40 sec at 100% 30-40 sec at 100% 45-55 sec at 100%	Place on paper towel.
<b>Vegetables</b> 1 serving 2 servings	Refrigerated Refrigerated	¾-1½ min at 100% 1½-2½ min at 100%	Cover. Stir after half the time.
<b>Baked Potato</b> 1 2	Refrigerated Refrigerated	1-2 min at 50% 2-3 min at 50%	Cut potato lengthwise and then several times crosswise. Cover with wax paper.
<b>Breads</b> (Dinner or breakfast roll) 1 roll 2 rolls 4 rolls	Room temp Room temp Room temp	8-12 sec at 50% 11-15 sec at 100% 18-22 sec at 100%	Wrap single roll, bagel or muffin in paper towel. To reheat several, line plate with paper towel. Cover with another paper towel.
<b>Pie</b> Whole 1 slice	Refrigerated Refrigerated	5-7 min at 70% 30 sec at 100%	

## Microwave cooking chart

Times are approximate and may need to be adjusted to individual taste.

<b>MEATS, POULTRY, FISH, SEAFOOD</b> Allow standing time after cooking.			<b>VEGETABLES (continued)</b> Cook at 100% Cook Power.	
FOOD	COOK POWER	TIME	FOOD	TIME
<b>Bacon</b>	100%	45 sec to 1 min 15 sec per slice	<b>Carrots (1 lb)</b>	8-12 min
<b>Ground Beef for Casseroles (1 lb)</b>	100%	4-6 min	<b>Cauliflower (medium head)</b>	6-9 min
<b>Hamburger Patties (2)</b>	100%	1st side 2 min 2nd side 1½ to 2½ min	<b>Corn on the Cob (2)</b>	4-9 min
<b>Hamburger Patties (4)</b>	100%	1st side 2½ min 2nd side 2-3 min	<b>(4)</b>	6-16 min
<b>Meat Loaf (1½ lbs)</b>	100%	13-19 min	<b>Potatoes, Baked (4 medium)</b>	13-19 min
<b>Chicken Pieces</b>	100%	6-9 min/lb	<b>Squash, Summer (1 lb)</b>	3-8 min
Internal temperature should be 185°F after standing.			<b>OTHER</b>	
<b>Turkey Breast</b>	100% then 70%	5 min 8-12 min/lb	<b>FOOD</b>	<b>COOK POWER</b>
Internal temperature should be 185°F after standing.			<b>TIME</b>	
<b>Fish Fillets (1 lb)</b>	100%	5-6 min	<b>Applesauce (4 servings)</b>	100% 7-10 min
<b>Scallops and Shrimp (1 lb)</b>	100%	3½-5½ min	<b>Baked Apples (4)</b>	100% 4-6 min
<b>VEGETABLES</b> Cook at 100% Cook Power.			<b>Chocolate (melt 1 square)</b>	50% 1-2 min
<b>FOOD</b>		<b>TIME</b>	<b>Eggs, Scrambled (2)</b>	100% 1 min 15 sec to 1 min 45 sec
<b>Beans, Green or Yellow (1 lb)</b>		6-12 min	<b>(4)</b>	2-3 min
<b>Broccoli (1 lb)</b>		6-10 min	<b>Hot Cereals (1 serving)</b>	100% 1½-5 min
			<b>(4 servings)</b>	4½-7 min
			<b>Nachos (large plate)</b>	50% 1½-2½ min
			<b>Water for Beverage (1 cup)</b>	100% 2½-4 min
			<b>(2 cups)</b>	4½-6 min

### Microwave cooking tips

#### Amount of food

- **The more food** you want to prepare, the longer it takes. A rule of thumb is that a double amount of food requires almost double the time. If one potato takes four minutes to cook, you need about seven minutes to cook two potatoes.

#### Starting temperature of food

- **The lower the temperature** of the food being put into the microwave oven, the longer it takes to cook. Food at room temperature will be reheated more quickly than food at refrigerator temperature.

#### Composition of food

- **Food with a lot of fat and sugar** will be heated faster than food containing a lot of water. Fat and sugar will also reach a higher temperature than water in the cooking process.
- **The more dense the food**, the longer it takes to heat. "Very dense" food like meat takes longer to reheat than lighter, more porous food like sponge cakes.

#### Size and shape

- **Smaller pieces of food** will cook faster than larger pieces and same-shaped pieces of food cook more evenly than irregularly shaped foods.
- **With unevenly shaped foods**, the thinner parts will cook faster than the thicker areas. **Place** the thinner parts of chicken wings and legs in the center of the dish.

#### Stirring, turning foods

- **Stirring and turning foods** distributes heat quickly to the center of the dish and avoids overcooking at the outer edges of the food.

#### Covering food

##### Cover food to:

- **Reduce** splattering
- **Shorten** cooking times
- **Retain** food moisture

All coverings that allow microwaves to pass through are suitable.

#### Releasing pressure in foods

- **Several foods** (for example: baked potatoes, sausages, egg yolks, and some fruits) are tightly covered by a skin or membrane. This can cause the food to burst from steam building up in them during cooking. To relieve the pressure and to prevent bursting, **prick** these foods with a fork, cocktail pick or toothpick.

#### Using standing time

- **Always allow food to stand** for a while after cooking. Standing time after defrosting, cooking, or reheating always improves the result since the temperature will then be evenly distributed throughout the food.
- **When cooking in a microwave oven**, food continues to cook even when the microwave energy is turned off. Food is no longer cooked by microwaves, but it is still being cooked by the high heat left over from the microwave oven.
- **The length of the standing time** depends on the volume and density of the food. Sometimes it can be as short as the time it takes you to remove the food from the oven and take it to the serving table. However, with larger, denser food, the standing time may be as long as 10 minutes.

**Arranging food**

For best results, distribute food evenly on the plate. You can do this in several ways:

- **If you are cooking several items of the same food**, such as baked potatoes, place them in a ring pattern for uniform cooking.
- **When cooking foods of uneven shapes or thickness**, place the smaller or thinner area of the food towards the center of the dish where it will be heated last.
- **Arrange uneven foods**, such as fish, in the oven with the tails to the center.
- **If you are saving a meal in the refrigerator or “plating” a meal for reheating**, arrange the thicker, denser foods to the outside of the plate and the thinner or less dense foods in the middle.
- **Place thin slices of meat** on top of each other or interlace them.
- **Place thicker slices of meat**, such as meat loaf and sausages, close to each other.
- **Reheat gravy or sauce** in a separate container.
- **When you cook or reheat whole fish**, score the skin – this prevents cracking.
- **Shield the tail and head of whole fish** with small pieces of foil to prevent overcooking and ensure the foil does not touch the sides of the oven.
- **Do not** let food or container touch the top or sides of the oven. This will prevent possible arcing.

**Using aluminum foil**

Metal containers usually should not be used in a microwave oven. There are, however, some exceptions. If you have purchased food which is prepackaged in an aluminum foil container, then refer to the instructions on the package. It is possible to use disposable containers, but it generally takes longer and the final result will not be as good as if food were placed in plastic or paper containers.

If you use aluminum containers without package instructions, follow these guidelines:

- **Place** container in a glass bowl and add some water so that it covers the bottom of the container, not more than ¼ inch high. This ensures even heating of the container bottom.
- **Always remove** the lid to avoid damage to the oven.
- **Use only** undamaged containers.
- **Do not use** containers taller than ¾".
- **Container must be** half filled.
- **To avoid sparking**, there must be a minimum ¼" between the aluminum container and the walls of the oven and also between two aluminum containers.
- **Always place** container on turntable.
- **Thickness of the food layer** must be greater than thickness of the aluminum.
- **Reheating food** in aluminum foil containers usually takes up to double the time compared to reheating in plastic, glass, china, or paper containers. The time when food is ready will vary a great deal.
- **Let food stand** for 2-3 minutes after heating so that heat is spread evenly throughout container.

**Cooking you should not do in your microwave oven**

- **Do not** do canning of foods in the oven. Closed glass jars may explode, resulting in damage to the oven or possible personal injury.
- **Do not** use the oven to sterilize objects (baby bottles, etc.). It is difficult to maintain the high temperature required for safe sterilization.

# Questions And Answers

QUESTIONS	ANSWERS
Can I operate my microwave oven without the turntable or turn the turntable over to accommodate a large dish?	No. If you remove or turn over the turntable, you will get poor cooking results. Dishes used in your oven must fit on the turntable.
Can I use a rack in my microwave oven so that I may reheat or cook on two levels at a time?	You can use a rack only if rack is supplied with your microwave oven. Use of any rack not supplied with the microwave oven can result in poor cooking performance and/or arcing.
Can I use either metal or aluminum pans in my microwave oven?	Useable metal includes aluminum foil for shielding (use small, flat pieces), small skewers and shallow foil trays (if tray is $\frac{3}{4}$ inch deep and filled with food to absorb microwave energy). Never allow metal to touch walls or door. (For more information, see page 35.)
Is it normal for the turntable to turn in either direction?	Yes. The turntable rotates clockwise or counterclockwise, depending on the rotation of the motor when the cooking cycle begins.
Sometimes the door of my microwave oven appears wavy. Is this normal?	This appearance is normal and does not affect the operation of your oven.
What are the humming noises that I hear when my microwave oven is operating?	You hear the sound of the transformer when the magnetron tube cycles on.
Why does the dish become hot when I microwave food in it? I thought that this should not happen.	As the food becomes hot it will conduct the heat to the dish. Be prepared to use hot pads to remove food after cooking.
What does "standing time" mean?	"Standing time" means that food should be taken out of the oven and covered for additional time after cooking. This process allows the cooking to finish, saves energy and frees the oven for another purpose.
Can I pop popcorn in my microwave oven? How do I get the best results?	Yes. Pop packaged microwave popcorn following manufacturer's guidelines or use the preprogrammed Popcorn pad. Do not use regular paper bags. Use the "listening test" by stopping the oven as soon as the popping slows to a "pop" every one or two seconds. Do not try to repop unpopped kernels. You can also use special microwave poppers. When using a popper, be sure to follow manufacturer's directions. Do not pop popcorn in glass utensils. Use care when popping 3.5 oz bags of popcorn; because of large size of bag and small size of oven cavity, bag can become stuck between turntable and oven wall.
Why does steam come out of the air exhaust vent?	Steam is normally produced during cooking. The microwave oven has been designed to vent this steam out the bottom and side vents.

# If You Need Assistance Or Service

This section is designed to help you save the cost of a service call. Part 1 of this section outlines possible problems, their causes, and actions you can take to solve each problem. Parts 2 and 3 tell you what to do if you still need assistance or service. When calling our Consumer Assistance Center for help or calling for service, please provide a detailed description of the problem, your appliance's complete model and serial numbers and the purchase date. (See page 2.) This information will help us respond properly to your request.

## 1. Before calling for assistance ...

Performance problems often result from little things you can find and fix without tools of any kind. Please check the chart below for problems you can fix. It could save you the cost of a service call.

PROBLEM	POSSIBLE CAUSE	SOLUTION
<b>Nothing will operate</b>	The power supply cord is not plugged into a live circuit with the proper voltage. A household fuse has blown or a circuit breaker has tripped. The electric company has experienced a power failure.	Plug power supply cord into a live circuit with the proper voltage. (See pages 7 and 9.) Replace household fuse or reset circuit breaker. Check electric company for a power failure.
<b>The microwave oven will not run</b>	The door is not firmly closed and latched. You did not touch START/ENTER. You did not follow directions exactly. An operation that was programmed earlier is still running.	Firmly close and latch door. Touch START/ENTER. Check instructions for the function you are operating. Touch OFF/CANCEL to cancel previous programming.
<b>Turntable will not turn</b>	Turntable is not correctly in place. Support is not operating correctly.	Make sure turntable is correct-side up and is sitting securely on center shaft. Remove turntable and restart oven. If turntable support does not move, call an authorized Whirlpool service technician for repair. Cooking without the turntable can give you poor results.

continued on next page

## IF YOU NEED ASSISTANCE OR SERVICE

PROBLEM	POSSIBLE CAUSE	SOLUTION
<b>The Display shows a time counting down but the oven is not cooking</b>	<p>The oven door is not closed completely.</p> <p>You have set the controls as a minute timer.</p>	<p>Completely close oven door.</p> <p>Touch OFF/CANCEL to cancel the Minute Timer.</p>
<b>You do not hear the Programming Tone</b>	<p>The command is not correct.</p>	<p>Re-enter command.</p>
<b>The fan seems to be running slower than usual</b>	<p>The oven has been stored in a cold area.</p>	<p>The fan will run slower until the oven warms up to normal room temperature.</p>
<b>The Display shows "0"</b>	<p>There has been a power interruption.</p>	<p>Reset the clock.</p>
<b>Microwave cooking times seem too long</b>	<p>The electric supply to your home or wall outlets is low or lower than normal.</p> <p>The Cook Power is not at the recommended setting.</p> <p>There is not enough cooking time for the amount of food being cooked.</p>	<p>Your electric company can tell you if the line voltage is low. Your electrician or service technician can tell you if the outlet voltage is low.</p> <p>Check "Microwave cooking chart" on page 33.</p> <p>Allow for more time when cooking more food at one time.</p>

## IF YOU NEED ASSISTANCE OR SERVICE

### 2. If you need assistance ...

Call Whirlpool Consumer Assistance Center telephone number. Dial toll-free from anywhere in the U.S.A.:

1-800-253-1301

and talk with one of our trained consultants. The consultant can instruct you in how to obtain satisfactory operation from your appliance or, if service is necessary, recommend a qualified service company in your area.

If you prefer, write to:

Mr. William Clark  
Consumer Assistance Representative  
Whirlpool Corporation  
2000 N State Route 63  
Benton Harbor, MI 49022-2692

Please include a daytime phone number in your correspondence.

### 3. If you need service ...



Whirlpool has a nationwide network of authorized Whirlpool® service companies. Whirlpool

service technicians are trained to fulfill the product warranty and provide after-warranty service, anywhere in the United States. To locate the authorized Whirlpool service company in your area, call our Consumer Assistance Center telephone number (see Step 2) or look in your telephone directory Yellow Pages under:

• **APPLIANCE-HOUSEHOLD-MAJOR, SERVICE & REPAIR**

- See: Whirlpool Appliances or Authorized Whirlpool Service  
(Example: XYZ Service Co.)

• **WASHING MACHINES & DRYERS, SERVICE & REPAIR**

- See: Whirlpool Appliances or Authorized Whirlpool Service  
(Example: XYZ Service Co.)

### 4. If you are not satisfied with how the problem was solved ...

- Contact the Major Appliance Consumer Action Panel (MACAP). MACAP is a group of independent consumer experts that voices consumer views at the highest levels of the major appliance industry.
- Contact MACAP only when the dealer, authorized servicer and Whirlpool have failed to resolve your problem.  
Major Appliance Consumer Action Panel  
20 North Wacker Drive  
Chicago, IL 60606
- MACAP will in turn inform us of your action.

# WHIRLPOOL®

## Microwave Oven Warranty

LENGTH OF WARRANTY	WHIRLPOOL WILL PAY FOR
<b>FULL ONE-YEAR WARRANTY</b> From Date of Purchase	FSP® replacement parts and repair labor to correct defects in materials or workmanship. Service must be provided by an authorized Whirlpool® service company.
<b>LIMITED FOUR-YEAR WARRANTY</b> Second Through Fifth Year From Date of Purchase	FSP replacement magnetron tube on microwave ovens if defective in materials or workmanship.
WHIRLPOOL WILL NOT PAY FOR	
<p><b>A. Service calls to:</b></p> <ol style="list-style-type: none"> <li>1. Correct the installation of your microwave oven.</li> <li>2. Instruct you how to use your microwave oven.</li> <li>3. Replace house fuses or correct house wiring.</li> <li>4. Replace owner accessible light bulbs.</li> </ol> <p><b>B. Repairs when your microwave oven is used in other than normal, single-family household use.</b></p> <p><b>C. Pickup and delivery.</b> Your microwave oven is designed to be repaired in the home.</p> <p><b>D. Damage to your microwave oven caused by accident, misuse, fire, flood, acts of God or use of products not approved by Whirlpool.</b></p> <p><b>E. Any labor costs during limited warranty.</b></p> <p><b>F. Repairs to parts or systems caused by unauthorized modifications made to the appliance.</b></p>	

5/93

WHIRLPOOL CORPORATION SHALL NOT BE LIABLE FOR INCIDENTAL OR CONSEQUENTIAL DAMAGES. Some states do not allow the exclusion or limitation of incidental or consequential damages, so this limitation or exclusion may not apply to you. This warranty gives you specific legal rights, and you may also have other rights which vary from state to state.

Outside the United States, a different warranty may apply. For details, please contact your authorized Whirlpool distributor or military exchange.

If you need service, first see the "If You Need Assistance Or Service" section of this book. After checking "If You Need Assistance Or Service," additional help can be found by calling our Consumer Assistance Center telephone number, 1-800-253-1301, from anywhere in the U.S.A.

**PART NO. 3874W500630/4358588**

© 1994 Whirlpool Corporation

© Registered Trademark of Whirlpool, U.S.A.

Printed in Korea